

CREATIVE MINES LLC | 5840 El Camino Real Suite 106

Carlsbad California 92008 | 800 453 7040 | creativemines.us



Attachment of Exterior Masonry Veneer through Expanded Polystyrene (EPS) to Wood or Steel Wall Framing



Visit www.creativemines.us for product installation instructions a current list of Dealers and Distributors. Creative Mines Craft Masonry Veneer is hand-designed and handcrafted. It looks like the real thing, so natural variations in color will occur. You should demand that of your crafted masonry veneer. Anything less would be unnatural. Measurements listed are averages and individual product may vary in dimension and weight while maintaining accordance with ASTM specifications. For submittal information and test data please consult your Creative Mines Representative. Creative Mines maintains the right to revise packaging and products inventoried. © 2019 CREATIVE MINES, INC. 011519



Attachment of Exterior Wall Coverings Through Expanded Polystyrene (EPS) to Wood or Steel Wall Framing

DRR No. 1506-05

Expanded Polystyrene (EPS) Producing FSC Members

Issue Date: July 2, 2015

Atlas Roofing Corporation – atlasroofing.com, atlaswallci.com, atlaseps.com
Dow Building Solutions – building.dow.com

DIVISON: 07 00 00 – THERMAL AND MOISTURE PROTECTION

Section: 07 21 00 – Building Insulation

Section: 07 40 00 – Roofing and Siding Panels

Section: 07 46 00 – Siding

1. Code Compliance Process Evaluated:

- 1.1. Attachment of exterior wall coverings through Expanded Polystyrene (EPS) Foam Plastic Insulating Sheathing (FPIS) to wood or steel wall framing
- 1.2. For the most recent version of this report, visit drjengineering.org. For more detailed state professional engineering and code compliance legal requirements and references, visit drjengineering.org/statelaw. DrJ is fully compliant with all state professional engineering and code compliance laws.

2. Applicable Codes and Standards:¹

- 2.1. *2009, 2012 and 2015 International Building Code (IBC)*
- 2.2. *2009, 2012 and 2015 International Residential Code (IRC)*
- 2.3. *2009, 2012 and 2015 International Energy Conservation Code (IECC)*
- 2.4. *ANSI/SBCA FS100 – Standard Requirements for Wind Pressure Resistance of Foam Plastic Insulating Sheathing Used in Exterior Wall Covering Assemblies*
- 2.5. *ASCE 7 – Minimum Design Loads for Buildings and Other Structures*
- 2.6. *National Design Specification for Wood Construction (NDS)*
- 2.7. *AISI Standard S100 – North American Specification for the Design of Cold-Formed Steel Structural Members*

¹ Unless otherwise noted, all references in this research report are from the 2012 version of the codes and the standards referenced therein, including, but not limited to, *ASCE 7*, *SDPWS* and *WFCM*. This product also complies with the 2000-2009 and 2015 versions of the *IBC* and *IRC* and the standards referenced therein. As required by law, where this research report is not approved, the building official shall respond in writing, stating the reasons this research report was not approved.

DrJ Research Report

3. Evaluation Scope:

- 3.1. This research report examines the attachment of exterior wall coverings through EPS, with thickness up to 4", to wood or cold-formed steel wall studs.
- 3.2. This research report also provides a step-by-step approach for the design process of attaching exterior wall coverings through EPS to wood or steel wall framing.
- 3.3. This evaluation and design methodology considers only the weight of the exterior covering on fasteners cantilevered through the EPS and into the stud.
- 3.4. Wind pressure resistance of the exterior covering is outside the scope of this research report. Consult the exterior covering manufacturer's installation instructions for information regarding the allowable design wind pressure for a given product in accordance with *ANSI/SBCA FS100*.
 - 3.4.1. The intent of this research report is not to reduce minimum fastener sizes, penetrations and spacings required to resist wind loads. Where fastener requirements for wind or cladding weight are more stringent, they shall control the design.
- 3.5. Attachment of window flanges over EPS is outside the scope of this research report.
- 3.6. Any code compliance issues not specifically addressed in this section are outside the scope of this evaluation.

4. Product Description and Materials:

- 4.1. EPS products used in accordance with this research report shall comply with the following material standards:
 - 4.1.1. EPS manufactured in compliance with *ASTM C578*.
- 4.2. EPS products used in accordance with this research report shall have a minimum compressive strength of 15 psi.
- 4.3. Where wind pressure resistance is required, EPS products used in accordance with this research report shall comply with *ANSI/SBCA FS100*.
- 4.4. EPS products are produced under proprietary manufacturing processes and are formed into rigid insulation panels.
- 4.5. EPS products are typically available in the following sizes:
 - 4.5.1. Thicknesses range from ½" to 6".
 - 4.5.2. The standard product width is 48".
 - 4.5.3. Standard lengths include 96", 108" and 120".
- 4.6. Consult the manufacturer for the availability of a given product with non-standard width or length.
- 4.7. The following EPS products meet the requirements of [Section 4.1](#) and [4.2](#):
 - 4.7.1. Atlas Roofing Corporation – “ThermalStar LCI” and “ThermalStar Chrome”

5. Applications:

- 5.1. Design Procedure
 - 5.1.1. Determine an appropriate cladding attachment requirement in accordance with [Section 5.2](#) through [5.4](#).
- 5.2. Select one of the following methods of cladding attachment:
 - 5.2.1.1. Direct attachment of cladding through EPS to wall framing, [Figure 1a](#).
 - 5.2.1.2. Furring attachment through EPS to wall framing, [Figure 1b](#), whereby cladding is attached to furring in accordance with the applicable building code and the cladding manufacturer's installation instructions.

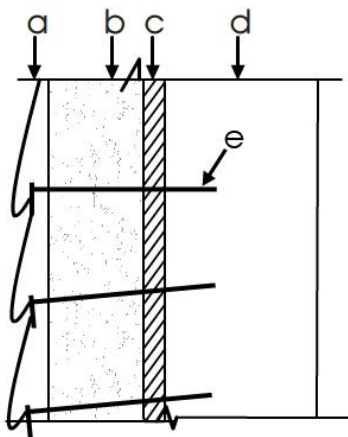

Exterior Wall Covering Assembly (direct attachment):

- a – Cladding material and fasteners
- b – Thickness of EPS, as required
- c – Optional wall sheathing or as required by the applicable building code (e.g., gypsum sheathing, WSP or other)²
- d – Wall framing per code (i.e., wood or cold-formed steel studs)
- e – Fastener per [Table 1a](#) or by design

Figure 1a: Illustration of Exterior Wall Covering Assembly Components (direct attachment)
 Note: Wall sheathing layer “c” is optional, unless required by the applicable building code.

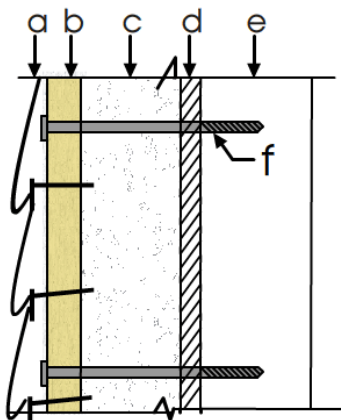

Exterior Wall Covering Assembly (through furring):

- a – Cladding material and fasteners
- b – Min 3/4"-thick (nominal 1x3 or larger) wood furring or min. 3/4" plywood (Exterior 1)³
- c – Thickness of EPS, as required
- d – Optional wall sheathing or as required by the applicable building code (e.g., gypsum sheathing, WSP or other)⁴
- e – Wall framing per code (i.e., wood or cold-formed steel studs)
- f – Fastener per [Table 1b](#) or by design

Figure 1b: Illustration of Exterior Wall Covering Assembly Components (through furring)
 Note: Wall sheathing layer “d” is optional unless required by the applicable building code.

5.3. From [Table 1a](#) for “direct attachment” method or [Table 1b](#) for “furring attachment” method, determine the maximum allowable EPS thickness based on a selected minimum fastener size, maximum fastener spacing and the cladding system weight.

- 5.3.1. To determine cladding system weight, add the weight of all materials on the exterior side of the foam sheathing (see ‘a’ in [Figure 1a](#) and ‘a’ and ‘b’ in [Figure 1b](#)).
- 5.3.2. Use actual weights for the materials installed. Actual cladding weights of materials can be obtained from the cladding manufacturer’s material specifications. Other typical weights of building materials can be found in the Commentary to *ASCE 7-10*. (See [Appendix A](#) for an excerpt from *ASCE 7-10*, Table C3-1 and other weight of materials references.)

² For compliance with the 2015 IRC and IBC, where a separate structural sheathing layer is not provided to separately resist wind load, the FPIS must comply with ANSI/SBCA FS100.
³ Siding fastening into a suitable nail-base sheathing shall be permitted for claddings not weighing more than 3 psf and foam sheathing thicknesses not greater than 2"; refer to 2015 IRC Section R703 for requirements.
⁴ Minimum required furring thickness may increase where cladding fastening requirements dictate more penetration depth in framing; alternatively, a compatible siding fastener with adequate withdrawal resistance shall be specified.

DrJ Research Report

Cladding Fastener Through Foam Plastic Sheathing into:	Siding Fastener – Type & Minimum Size	Siding Fastener Vertical Spacing (in.)	Maximum Thickness of Foam Plastic Insulating Wall Sheathing (in.)					
			16" o.c. Fastener Horizontal Spacing			24" o.c. Fastener Horizontal Spacing		
			Max Cladding Weight:			Max Cladding Weight:		
			3 psf	11 psf	25 psf	3 psf	11 psf	25 psf
Wood Framing (minimum 1 1/4" penetration)	0.113" diameter nail	6	2	1	DR	2	0.75	DR
		8	2	1	DR	2	0.5	DR
		12	2	0.5	DR	2	DR	DR
	0.120" diameter nail	6	3	1.5	0.5	3	0.75	DR
		8	3	1	DR	3	0.5	DR
		12	3	0.5	DR	2	DR	DR
	0.131" diameter nail	6	4	2	0.75	4	1	DR
		8	4	1.5	0.5	4	0.75	DR
		12	4	0.75	DR	2	0.5	DR
	0.162" diameter nail	6	4	4	1.5	4	2	1
		8	4	3	1	4	1.5	0.75
		12	4	2	0.75	4	1	DR
Steel Framing (minimum penetration of steel thickness + 3 threads)	#8 screw into 33 mil steel or thicker	6	3	3	1.5	3	2	DR
		8	3	2	0.5	3	1.5	DR
		12	3	1.5	DR	3	0.75	DR
	#10 screw into 33 mil steel	6	4	3	2	4	3	0.5
		8	4	3	1	4	2	DR
		12	4	2	DR	3	1	DR
	#10 screw into 43 mil steel or thicker	6	4	4	3	4	4	2
		8	4	4	2	4	3	1.5
		12	4	3	1.5	4	3	DR

For SI: 1" = 25.4 mm; 1 pound per square foot [psf] = 0.0479 kPa

1. Tabulated requirements are based on wood framing of Spruce-Pine-Fir or any wood species with a specific gravity of 0.42 or greater in accordance with AWC/NDS® and minimum 33 ksi steel for 33 mil and 43 mil steel and 50 ksi steel for 54 mil steel or thicker.
2. See [Appendix A](#) for information on how the table values were derived.
3. Cladding weight shall include all materials supported by the fasteners on the exterior side of the foam sheathing (e.g., wood structural panel sheathing may be installed between the cladding material and the foam sheathing). In such cases, both the cladding and the WSP sheathing weight must be included in the calculation for the cladding weight.
4. Examples of cladding included in each weight category: 3 psf – vinyl siding, 11 psf – fiber cement siding, 25 psf – masonry or cultured stone. Examples are not inclusive.
5. Nail fasteners shall comply with *ASTM F1667*, except nail length shall be permitted to exceed *ASTM F1667* standard lengths. Screws shall comply with *ASTM C1513*.
6. Self-drilling tapping screw fasteners for connection of siding to steel framing shall comply with the requirements of *AISI S200*. Other approved fasteners of equivalent or greater diameter and bending strength shall be permitted.
7. For cladding system weights exceeding 25 psf with any thickness of foam sheathing, a design professional should be consulted.
8. Table 1a solutions are limited to 4" maximum thickness of foam sheathing. Design is required for thicknesses of foam sheathing greater than 4".
9. Foam sheathing shall have a minimum compressive strength of 15 psi in accordance with *ASTM C578*.
10. Metal lath shall be minimum 2.5 lbs./yd.² diamond mesh in accordance with *ASTM C847*. Metal lath lock washers on fasteners are highly recommended.
11. Vertical spacing of fasteners in metal lath shall not exceed 7" o.c., in accordance with *ASTM C1063* and the Masonry Veneer Manufacturer Association (MVMA) Installation Guide.
12. Where adhered masonry is used, it shall be installed in accordance with the MVMA Installation Guide.
13. Linear interpolation between cladding weight categories is not permissible.
14. DR = Design Required

Table 1a: Siding Minimum Fastening Requirements for Direct Cladding Attachment Over Foam Plastic Sheathing to Support Cladding System Weight

DrJ Research Report

Furring Material	Framing Member	Fastener Type & Minimum Size	Minimum Penetration into Wall Framing (in.)	Fastener Spacing in Furring (in.)	Maximum Thickness of Foam Plastic Insulating Sheathing (in.)						Allowable Wind Pressure Resistance of Furring Attachment (psf)	
					16" o.c. Furring			24" o.c. Furring				
					Siding Weight:			Siding Weight:			16" o.c. Furring	24" o.c. Furring
					3 psf	11 psf	25 psf	3 psf	11 psf	25 psf		
Minimum 1x3 Wood Furring	Minimum 2x Wood Stud	Nail (0.120" shank; 0.271" head)	1 1/4"	8	2	1.5	0.5	2	1	DR	42.6	28.4
				12	2	1.5	DR	2	0.5	DR	28.4	18.9
				16	2	0.75	DR	2	DR	DR	21.3	14.2
		Nail (0.131" shank; 0.281" head)	1 1/4"	8	4	2	1	4	1.5	DR	46.5	31.0
				12	4	1.5	DR	3	1	DR	31.0	20.7
				16	4	1	DR	3	0.5	DR	23.3	15.5
		0.162" diameter nail	1 1/4"	8	4	4	1.5	4	2	0.75	57.5	38.3
				12	4	2	0.75	4	1.5	DR	38.3	25.6
				16	4	1.5	DR	4	1	DR	28.8	19.2
		#10 wood screw	1"	12	4	2	0.75	4	1.5	DR	107.3	71.6
				16	4	1.5	DR	4	1	DR	79.0	52.7
				24	4	1	DR	3	DR	DR	35.1	23.4
1/4" lag screw	1 1/2"	12	4	3	1	4	2	0.5	140.4	93.6		
		16	4	1.5	DR	4	1.5	DR	79.0	52.7		
		24	4	1.5	DR	4	0.75	DR	35.1	23.4		
Minimum 33mil Steel Hat Channel or Minimum 1x3 Wood Furring	33 mil Steel Stud	#8 screw (0.285" head)	Steel thickness +3 threads	12	3	1.5	DR	3	0.5	DR	52.9	35.3
				16	3	1	DR	2	DR	DR	39.7	26.5
				24	2	DR	DR	2	DR	DR	26.5	17.6
		#10 screw (0.333" head)	Steel thickness +3 threads	12	4	2	DR	4	1	DR	62.9	41.9
				16	4	1.5	DR	3	DR	DR	47.1	31.4
				24	3	DR	DR	2	DR	DR	31.4	21.0
	43 mil or thicker Steel Stud	#8 screw (0.285" head)	Steel thickness +3 threads	12	3	1.5	DR	3	0.5	DR	69.0	46.0
				16	3	1	DR	2	DR	DR	51.8	34.5
				24	2	DR	DR	2	DR	DR	34.5	23.0
		#10 screw (0.333" head)	Steel thickness +3 threads	12	4	3	1.5	4	3	DR	81.9	54.6
				16	4	3	0.5	4	2	DR	61.5	41.0
				24	4	2	DR	4	0.5	DR	35.1	23.4

For SI: 1" = 25.4 mm; 1 pound per square foot (psf) = 0.0479 kPa

- Table values are based on:
 - Minimum 3/4" (19.1 mm) thick wood furring and wood studs of Spruce-Pine-Fir or any softwood species with a specific gravity of 0.42 or greater per AF&PA/INDS®.
 - Minimum 33 mil steel hat channel furring of 33 ksi steel. Steel hat channel shall have a minimum 7/8" (22.2 mm) depth.
 - Steel framing of indicated nominal steel thickness and minimum 33 ksi steel for 33 mil and 43 mil steel and 50 ksi steel for 54 mil steel or thicker.
- Self-drilling, self-tapping screw fasteners for connection of siding to steel framing shall comply with the requirements of AISI S200. Other approved fasteners of equivalent or greater diameter and bending strength shall be permitted.
- Nail fasteners shall comply with ASTM F1667, except nail length shall be permitted to exceed ASTM F1667 standard lengths. Screws shall comply with ASTM C1513.
- Furring shall be spaced a maximum of 24" o.c. in a vertical or horizontal orientation.
 - In a vertical orientation, furring shall be located over wall studs and attached with the required fastener spacing.
 - Where placed horizontally, wood furring shall be preservative treated wood in accordance with IRC Section R317.1 or naturally durable wood and fasteners shall be corrosion resistant in accordance IRC Section R317.3. Steel furring shall have a minimum G60 galvanized coating.
 - Furring strips installed in a horizontal direction shall be fastened at each stud with a number of fasteners equivalent to that required by the fastener spacing. If the required nail spacing is 12" o.c. and the studs are 24" o.c., then two (2) nails would be required at each stud (24/12=2). In no case shall fasteners be spaced more than 24" (0.6 m) apart.
- Lag screws shall be installed with a standard cut washer.
- Lag screws and wood screws shall be pre-drilled in accordance with AF&PA/INDS®.
- Approved self-drilling screws of equal or greater shear and withdrawal strength shall be permitted without pre-drilling.
- A minimum 2x wood furring shall be used where the required siding fastener penetration into wood material exceeds 3/4" (19.1 mm) and is not more than 1 1/2" (38.1 mm), unless approved deformed shank siding nails or siding screws are used to provide equivalent withdrawal strength, allowing the siding connection to be made to a 1x wood furring.
- Examples of cladding included in each weight category: 3 psf – vinyl siding, 11psf – fiber cement siding, 25 psf – masonry or cultured stone. Examples are not inclusive.
- For cladding system weights exceeding 25 psf with any thickness of foam sheathing, a design professional should be consulted.
- Table 1b solutions are limited to 4" maximum thickness of foam sheathing. Design is required for thicknesses of foam sheathing greater than 4".
- Foam sheathing shall have a minimum compressive strength of 15 psi, in accordance with ASTM C578.
- Linear interpolation between cladding weight categories is not permissible.
- DR = Design Required

Table 1b: Furring Minimum Fastening Requirements for Application Over Foam Plastic Insulating Sheathing to Support Cladding System Weight & Resist Wind Pressure

DrJ Research Report

- 5.4. The minimum fastening requirement shall be the more stringent of that required by:
- 5.4.1. Fastening schedule determined in accordance with [Section 5.3](#) of this research report.
 - 5.4.2. Fastener type, head size, diameter, spacing, and penetration into framing required by the applicable building code for the specific cladding material and the cladding manufacturer's installation instructions^{5,6}.
 - 5.4.2.1. Where the seismic provisions of [IRC Section R301.2.2](#) apply, the wall assembly shall not exceed the weight limits of [Section R301.2.2.1](#), unless an engineered design is provided in accordance with [Section R301.1.3](#).
 - 5.4.2.2. Where the seismic load provisions of [IBC Section 1613](#) apply, the cladding attachment shall be verified to provide resistance to meet or exceed minimum required earthquake loads.
 - 5.4.3. Fastenings that are not at least equivalent to minimum required fastener characteristics described in [Section 5.4.2](#) shall be designed to provide adequate support of cladding weight, resistance to wind loading, and seismic loads as required by the applicable building code.
 - 5.4.4. For furring connections in accordance with [Table 1b](#), allowable wind load resistance shall be verified to meet or exceed the minimum required wind load of the applicable code:
 - 5.4.4.1. Refer to [IRC Table R301.2\(2\)](#) for components and cladding wind loads for the applicable wall wind zone and for an effective wind area of 10 square feet.
 - 5.4.4.2. For *IBC* required wind loads, see [IBC Section 1609](#).

6. Installation:

- 6.1. Verify that materials comply with the following provisions of this research report:
 - 6.1.1. EPS materials shall comply with the requirements of [Section 4](#), unless otherwise approved by the manufacturer evaluation report for the product and thickness intended.
- 6.2. Wall framing materials shall comply with [Section 5](#), specifically the minimum wood and cold-formed steel framing member requirements in the footnotes to [Table 1a](#) and [1b](#), as applicable.
- 6.3. Cladding or furring fastener type and size, including fastener length to obtain required penetration into or through framing members, complies with the solution determined in accordance with [Section 5.4](#).
 - 6.3.1. Where fasteners are permitted to penetrate into or fully through sheathing or nailable substrate without penetrating into framing, as specified by the manufacturer's instructions and supported by a test report, the end of the fastener shall extend a minimum of ¼" beyond the opposite face of the sheathing or nailable substrate in accordance with [IRC Section R703.11.1](#).
- 6.4. Fasteners shall be installed into framing members and driven flush and snug such that gaps between layers are removed, except where a gap under the cladding fastener head is required for attachment of vinyl siding.
- 6.5. Fasteners shall be installed in a workmanlike manner and not over-driven, resulting in material damage or excessive distortion of cladding, furring or EPS materials.
- 6.6. Ensure framing members or blocking are provided to allow for attachment of siding and trim materials at transitions such as corners and wall penetrations. Ensure that a code compliant water-resistive barrier system and flashing is provided prior to or during the installation of cladding materials.
- 6.7. Where required by contract documents, the project owner or owner's agent, or good practice, construct a mock-up assembly to demonstrate constructability and a proper integration of components.

⁵ An example of this would be lath attachments for stucco where a maximum of 7" o.c. spacing is required.

⁶ 2015 *IRC* Section R703.4 provides a new prescriptive table for the attachment of furring to resist up to 30 psf design wind loading.

DrJ Research Report

7. Test and Engineering Substantiating:

- 7.1. [ABTGRR No. 1503-02](#): Attachment of Exterior Wall Coverings Through Foam Plastic Insulating Sheathing (FPIS) to Wood or Steel Wall Framing, Applied Building Technology Group.
- 7.2. National Design Specification for Wood Construction – 2012 Edition, American Forest & Paper Association.
- 7.3. [General Dowel Equations for Calculating Lateral Connection Values](#) (2014), TR-12, American Forest & Paper Association.
- 7.4. North American Cold-Formed Steel Specification – 2012 Edition, American Iron & Steel Institute (AISI S100 standard).
- 7.5. [Fastening Systems for Continuous Insulation](#), New York State Energy Research and Development Authority 2010.
- 7.6. International Code Council, 2013 Public Comment Hearing Results to the International Residential Code-building, Proposal RB389, RB390.
- 7.7. The product(s) evaluated by this research report falls within the scope of one or more of the model, state or local building codes for building construction. The testing and/or substantiating data used in this research report is limited to buildings, structures, building elements, construction materials and civil engineering related specifically to buildings.
- 7.8. The provisions of model, state or local building codes for building construction do not intend to prevent the installation of any material or to prohibit any design or method of construction. Alternatives shall use consensus standards, performance-based design methods or other engineered alternative means of compliance. This research report assesses compliance with defined standards, generally accepted engineering analysis, performance-based design methods, etc. in the context of the pertinent building code requirements.
- 7.9. Some information contained herein is the result of testing and/or data analysis by other sources, which DrJ relies on to be accurate as it undertakes its engineering analysis.
- 7.10. DrJ has reviewed and found the data provided by other professional sources are credible. This information has been approved in accordance with DrJ's procedure for acceptance of data from approved sources.
- 7.11. DrJ's responsibility for data provided by approved sources is in accordance with professional engineering law.
- 7.12. Where appropriate, DrJ relies on the derivation of design values, which have been codified into law through codes and standards (e.g., *IRC*, *WFCM*, *IBC*, *SDPWS*, etc.). This includes review of code provisions and any related test data that helps with comparative analysis or provides support for equivalency to an intended end-use application.

8. Findings:

- 8.1. The design procedure and installation requirements outlined in this research report may be used to attach exterior wall coverings through foam sheathing to wood or steel wall framing.
- 8.2. 2015 *IRC* Section R703.3 and R703.15 through R703.16 (Appendix B) include provisions for the attachment of cladding and/or furring over EPS to appropriately resist the required design wind loads.
- 8.3. [IBC Section 104.11](#) and [IRC Section R104.11](#) ([IFC Section 104.9](#) is similar) state:

104.11 Alternative materials, design and methods of construction and equipment. The provisions of this code are not intended to prevent the installation of any material or to prohibit any design or method of construction not specifically prescribed by this code, provided that any such alternative has been *approved*. An alternative material, design or method of construction shall be *approved* where the *building official* finds that the proposed design is satisfactory and complies with the intent of the provisions of this code, and that the material, method or work offered is, for the purpose intended, at least the equivalent of that prescribed in this code. ... Where the alternative material, design or method of construction is not *approved*, the *building official* shall respond in writing, stating the reasons the alternative was not *approved*.⁷
- 8.4. This research report uses professional engineering law, the building code, ANSI/ASTM consensus standards and generally accepted engineering practice as its criteria for all testing and engineering analysis. DrJ's professional engineering work falls under the jurisdiction of each state Board of Professional Engineers, when signed and sealed.

⁷ The last sentence is adopted language in the 2015 codes.

DrJ Research Report

9. Conditions of Use:

- 9.1. Where required by the authority having jurisdiction (AHJ) in which the project is to be constructed, this report and the installation instructions of the cladding and EPS manufacturers shall be submitted at the time of permit application or available on site during inspection.
- 9.2. The attachment of cladding materials through the EPS described in this research report comply with the 2015 versions of the *IBC* and *IRC*, or are a code-compliant alternative as specified in the codes listed in [Section 2](#) subject to the following conditions:
 - 9.2.1. Installation shall comply with the manufacturer's installation instructions and this research report. In the event of a conflict between the manufacturer's installation instructions and this research report, the more restrictive shall govern.
 - 9.2.2. Installation shall be on exterior walls with code-compliant wood framing or cold-formed steel framing meeting the minimum requirements as indicated in [Table 1a](#) and [1b](#).
- 9.3. Design
 - 9.3.1. Building Designer Responsibility
 - 9.3.1.1. Unless the AHJ allows otherwise, the Construction Documents shall be prepared by a Building Designer (e.g., Owner, Registered Design Professional, etc.) for the Building and shall be in accordance with [IRC Section R106](#) and [IBC Section 107](#).
 - 9.3.1.2. The Construction Documents shall be accurate and reliable and shall provide the location, direction and magnitude of all applied loads and shall be in accordance with [IRC Section 301](#) and [IBC Section 1603](#).
 - 9.3.2. Construction Documents
 - 9.3.2.1. Construction Documents shall be submitted to the Building Official for approval and shall contain the plans, specifications and details needed for the Building Official to approve such documents.
- 9.4. Responsibilities
 - 9.4.1. The information contained herein is a product, engineering or building code compliance research report performed in accordance with the referenced building codes, testing and/or analysis through the use of accepted engineering procedures, experience and good technical judgment.
 - 9.4.2. Product, design and code compliance quality control are the responsibility of the referenced company. Consult the referenced company for the proper detailing and application for the intended purpose. Consult your local jurisdiction or design professional to assure compliance with the local building code.
 - 9.4.3. DrJ research reports provide an assessment of only those attributes specifically addressed in the Products Evaluated or Code Compliance Process Evaluated section.
 - 9.4.4. The engineering evaluation was performed on the dates provided in this research report, within DrJ's professional scope of work.
 - 9.4.5. The actual design, suitability and use of this research report for any particular building is the responsibility of the Owner, the Owner's authorized agent or the Building Designer.

10. Identification:

- 10.1. The foam sheathing described in this research report is identified by a label on the board or packaging material bearing the manufacturer's name, product name, label of the third-party inspection agency, and other information to confirm code compliance.

11. Review Schedule:

- 11.1. This research report is subject to periodic review and revision. For the most recent version of this report, visit drjengineering.org.
- 11.2. For information on the current status of this report, contact [DrJ Engineering](#).